



PRE – INSTALLATION

NOTE: The preparation of the site, in readiness for the installation of the appliance, is the responsibility of the site owner, not of the manufacturer of the appliance.

- a. The floor must be level and capable of supporting the weight of the cooker (approximate weight 300kg).
- b. The cooker measurements are 600mm deep and 900mm high to the working surface with a width of 890mm . The EVH 90i should be installed with a minimum of 30mm clearance from the back wall. **This 30mm gap is best sealed by running the worktop behind the cooker, though a standard 30mm stainless infill strip that fits to the back of the cooker can be bought from Everhot.** On no account should any Everhot model be pushed hard against the back wall as this may damage the electric cable. A minimum gap of 5mm per side is required to allow installation and removal of the cooker – please contact us in advance of installation if this is not possible. Where the end grain of a wooden worktop is adjacent to the cooker, we recommend that this is increased to 10mm to minimise the chance of the worktop splitting.
- c. Clearance must be allowed for the raising of the cooker lid into the upright position (minimum height of 1530mm from ground level). Please see side view diagrams for further clarification. A 5mm gap on each side of the cooker lid should be allowed when in the raised position (the lids are slightly inset from the side of the cooker to allow for overhead cupboards).
- d. The appliance must be used on 220-240V AC only and should be plugged into two standard 13 amp sockets. The 13 amp sockets should be accessible and positioned adjacent to the cooker, so as not to impede the opening of the top lid, and ensuring the plugs are not exposed to steam or excessive moisture. If the sockets cannot be positioned immediately adjacent to the cooker, please see diagrams attached for exact lengths of cables (unfortunately it is not possible to extend these cable lengths). If the power supply cord is damaged, it must be replaced by the manufacturer or their representative, as special purpose tools are required. **An Everhot cooker should NOT be hard wired – please install using the supplied 13amp plug.**

POST INSTALLATION

Point a. below will normally be checked by the **EVERHOT** technician who installs your cooker

- a. Before use, check that the cooker is level, upright and stable.
- b. On reaching working temperature, ensure that the hot/simmer plate surfaces are flush with the surrounds - this can be adjusted using a 5mm allen key in the bolts at each corner of the hotplates.
- c. On initial heating up odours may be given off from the insulants used. These will disappear after a number of hours.

Your **EVERHOT** cooker has been built to comply with the following European Directives, and carries the CE mark.

1. EMC Directive (2004/108/EC)
2. Low Voltage Directive (2006/95/EC)

Control of Substances - Health and Safety

This appliance contains the following substances indicated below. It is the User's/Installer's responsibility to ensure that the appropriate precautions are taken when handling, where applicable, any of the materials that could be interpreted as being injurious to health and safety.

Mineral wool, Glass Yarn.

May cause irritation to the skin, eyes, nose and throat, may be harmful if inhaled. Use appropriate protective clothing to avoid contact with body. After handling, wash hands and other exposed parts.

Your cooker does not contain ceramic insulants

The EVERHOT is a high quality appliance that will provide decades of use, however when you feel that it has reached the end of its working life, please contact us and we will remove it and recycle it free of charge



INSTALLATION INSTRUCTIONS & SPECIFICATION

EVH 90i

The diagrams below are not to scale and are simply to show the relevant dimensions – sockets can be placed either side of the cooker.

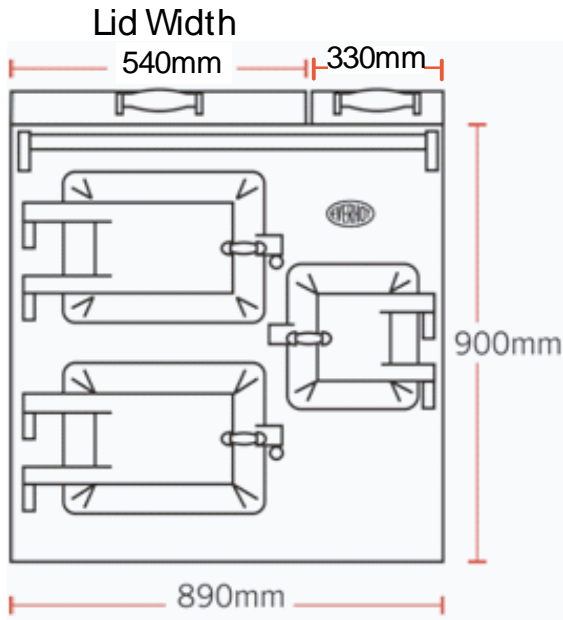

Cooker Width
EVH 90i

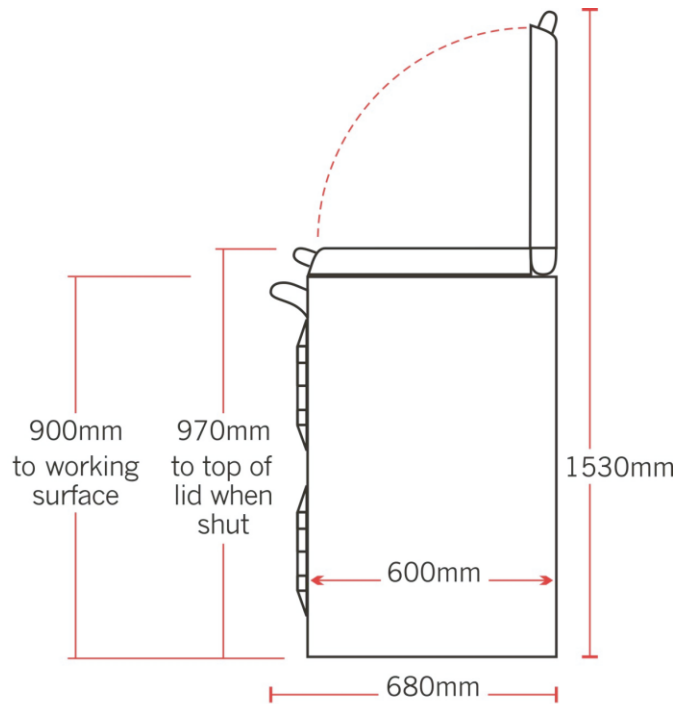

Side View EVH 90i

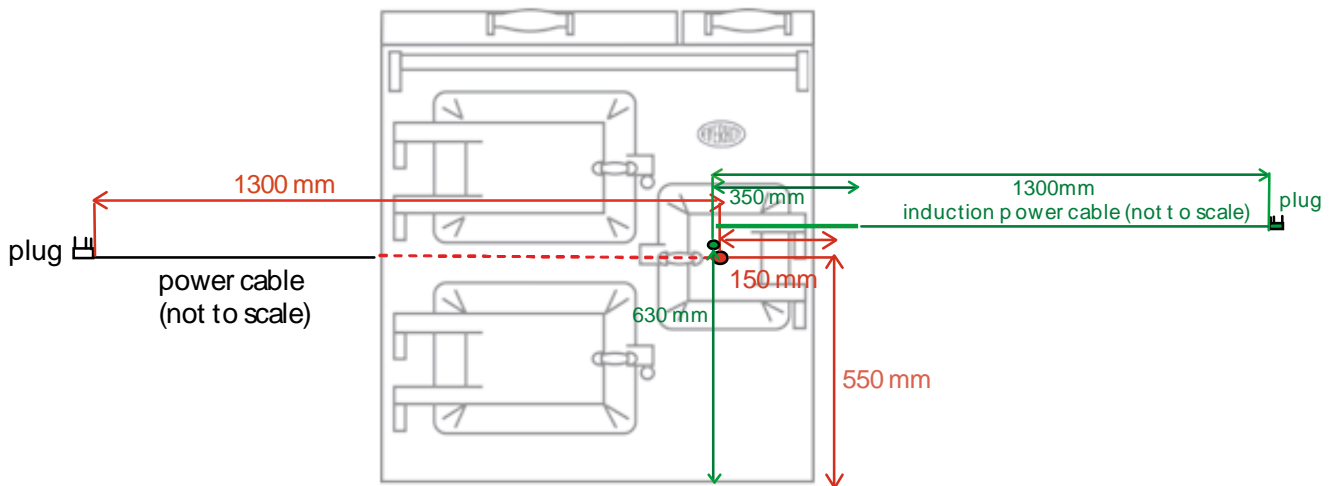

EVH 90i cable lengths