



PRE – INSTALLATION

NOTE: The preparation of the site, in readiness for the installation of the appliance, is the responsibility of the site owner, not of the manufacturer of the appliance.

- a. The floor **must be level** and capable of supporting the weight of the cooker (approximate weight 500kg).
- b. The cooker measurements are 600mm deep and 900mm high to the working surface with a width of 1198mm. The EVH 120 should be installed with a minimum of 30mm clearance from the back wall to allow for the electric cable entry. **This 30mm gap is best sealed by running the worktop behind the cooker, though a standard 30mm stainless infill strip that fits to the back of the cooker can be bought from Everhot.** On no account should the cooker be pushed hard against the back wall as this may damage the electric cable. A minimum gap of 5mm per side is required to allow installation and removal of the cooker – please contact us in advance of installation if this is not possible. Where the end grain of a wooden worktop is adjacent to the cooker, we recommend that this is increased to 10mm to minimise the chance of the worktop splitting.
- c. Clearance must be allowed for the raising of the cooker lid(s) into the upright position (minimum height of 1530mm from ground level). Please see side view diagrams for further clarification. A 5mm gap on the outside edges of the lids should be allowed when in the raised position (each lid is 590mm wide to allow for overhead cupboards).
- d. The appliance must be used on 220-240V AC only and should be plugged into two standard 13 amp sockets. The 13 amp sockets should be accessible and positioned adjacent to the cooker, so as not to impede the opening of the top lid, and ensuring the plug is not exposed to steam or excessive moisture. If the sockets cannot be positioned immediately adjacent to the cooker, please see diagrams attached for exact lengths of cables (unfortunately it is not possible to extend these cable lengths). If the power supply cord is damaged, it must be replaced by the manufacturer or their representative, as special purpose tools are required. **An Everhot cooker should NOT be hard wired – please install using the supplied 13amp plugs.**
- e. The Everhot 120 comes with two separate control boxes connected to the cooker via 20mm flexible conduits to allow for a choice of positioning. They may be sited within an adjacent cupboard or on a worktop as required (the control boxes must not be covered by combustible material or be positioned where contamination with liquids is likely). The control boxes are not suitable for wall mounting and should remain freestanding in order to facilitate future maintenance. The conduits and power cables should also be easily accessible. Once the positions have been decided the control boxes should not be moved in day to day use. Standard conduit lengths supplied are 2 metres (unfortunately it is not possible to extend these cable lengths). The control boxes should ideally be placed one either side of the cooker to ensure sufficient length of conduit for installation, each adjacent to a 13 amp socket. If this is not possible, please contact Everhot for further information. Where the control box leads are passing through a cupboard this can be done by our installers on delivery. If they need to pass through walls or thicker materials two 50mm diameter holes should be prepared in advance of the delivery.

POST INSTALLATION

Point a. below will normally be checked by the EVERHOT technician who installs your cooker

- a. Before use, check that the cooker is level, upright and stable.
- b. On reaching working temperature, ensure that the hot/simmer plate surfaces are flush with the surrounds - this can be adjusted using a 5mm allen key in the bolts at each corner of the hotplates.
- c. On initial heating up odours may be given off from the insulants used. These will disappear after a number of hours.

Your **EVERHOT** cooker has been built to comply with the following European Directives, and carries the CE mark.

1. EMC Directive (2004/108/EC)
2. Low Voltage Directive (2006/95/EC)

Control of Substances - Health and Safety

This appliance contains the following substances indicated below. It is the User's/Installer's responsibility to ensure that the appropriate precautions are taken when handling, where applicable, any of the materials that could be interpreted as being injurious to health and safety.

Mineral wool, Glass Yarn.

May cause irritation to the skin, eyes, nose and throat, may be harmful if inhaled. Use appropriate protective clothing to avoid contact with body. After handling, wash hands and other exposed parts.

Your cooker does not contain ceramic insulants.

The EVERHOT is a high quality appliance that will provide decades of use, however when you feel that it has reached the end of its working life, please contact us and we will remove it and recycle it free of charge



The diagrams below are not to scale and are simply to show the relevant dimensions – sockets can be placed either side of the cooker

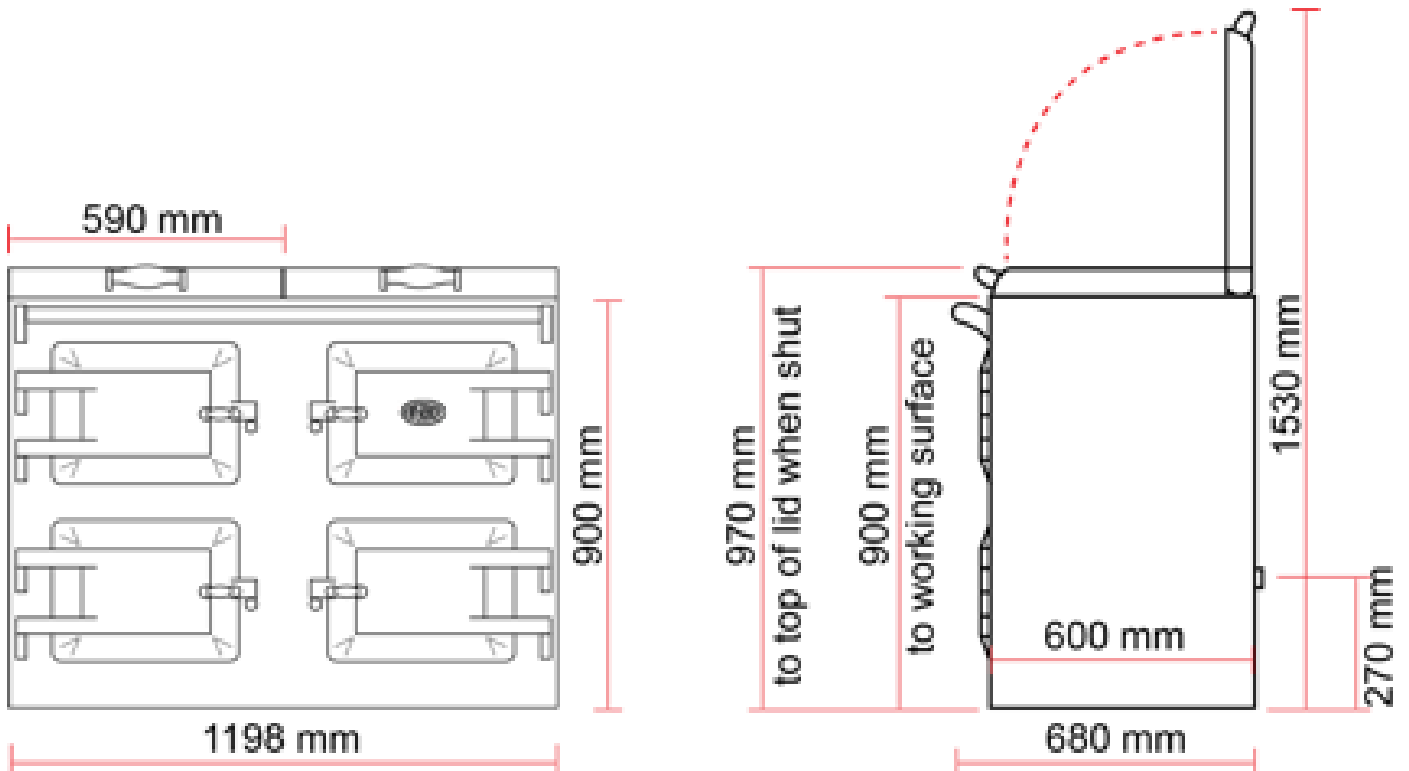

Front view EVH 120

Side view EVH 120

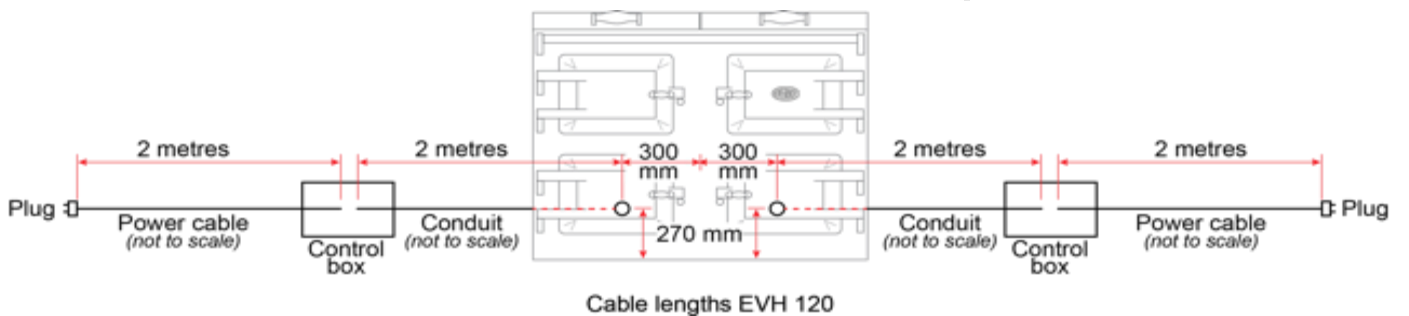

Cable lengths EVH 120

The control boxes should ideally be placed one either side of the cooker to ensure sufficient length of conduit for installation, each adjacent to a 13 amp socket. If this is not possible, please contact Everhot for further information.